

VISION:analog™

VCC-F40X34

**1/3" ANALOG
Color Camera**



XGA ANALOG COLOR CAMERA

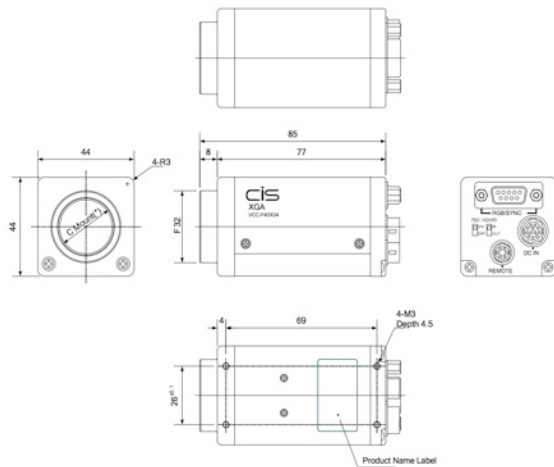

*1. C Mount screws comply with ANSI/ASME B1.1, 1-32UN (2B).

*2. Screw length from C mount lens surface shall be under 6mm. And, protruding portion shall be less than 10mm.



SPECIFICATIONS

RESOLUTION	XGA
SENSOR TYPE	1/3" SONY ICX204AK CCD
FRAME RATE	30fps
POWER CONSUMPTION	2.8W
INPUT VOLTAGE	DC+12V ±10% (Max 15V)
OPERATING CONDITIONS	0°C ~40°C @ 20~80% (no condensation)
WEIGHT	170g
LENS MOUNT	C MOUNT
VIDEO OUTPUT SIGNAL	VS Output 1Vp-p (negative sync)
NUMBER OF EFFECTIVE PIXELS	1034(H)×779(V)
HORIZONTAL SCAN FREQUENCY	23.622kHz
PIXEL CLOCK	30MHz
PIXEL SIZE	4.65 x 4.65 (µm)
MINIMUM ILLUMINATION	F1.4 @ 25lx
SENSITIVITY	F5.6 @ 2000lx
STANDARD COLOR TEMPERATURE	2600~9000K
GAIN	0~12dB (guaranteed range)
ELECTRONIC SHUTTER	1/30 (Off) ~ 1/10000 sec.
SYNC. METHOD	Internal Sync. External Sync. HD/VD
EXTERNAL TRIGGER	Fixed Shutter Exposure/Pulse Width Exposure



701 Fifth Ave
Suite 4620
Seattle, WA 98104
800-431-CISA
www.cis-americas.com

